



Premium Deck Mounts

Features

Rugged and heavy duty mounts are intended for deck and mast installations. The cable is protected inside the mount with direct feed through the deck or mast.

This mount is made from the highest quality Marine Grade Stainless Steel to withstand harsh weather conditions and prevent corrosion at sea.

Application

- Deck Installations
- Mast Installations

Ordering Information

Product Code	Description
ACW-650	Mobility thread to HD Dome
ACW-651	1" 14 TPI female to Mobility thread
ACW-652	1" 14 TPI male adapter



Overview



Compatible with MAX HD Dome series

Order Suggestion

With Maritime base: ACW-650 + ACW-651 + ACW-652

Without Maritime base: ACW-650 + ACW-651

Order Suggestion

With Maritime base: ACW-651 + ACW-652
Without Maritime base: ACW-651

* Not compatible with Mobility 42G.



Compatible with Mobility antenna series



Compatible with Maritime antenna series

Order Suggestion

ACW-652

* The Deck Mount Set is included in the Maritime 40G Antenna Package.

ACW-650

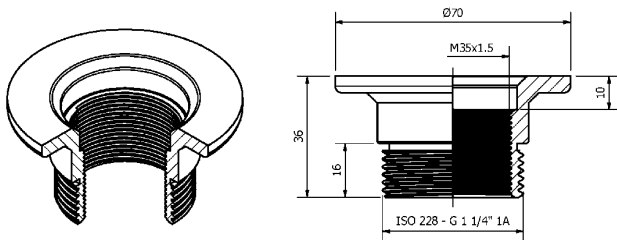

Mechanical Specification

Material: Stainless Steel SS316
Internal thread: M35x1.5 (compliant with HD Dome)
External thread: 1"14 TPI (fits to ACW-651)
Dimensions HxD: 1.42" x 2.76" (36 x 70mm)
Weight: 220g / 0.49 pounds

Order Information

Product Code	Description
ACW-650	Mobility thread to HD2 Dome

ACW-651

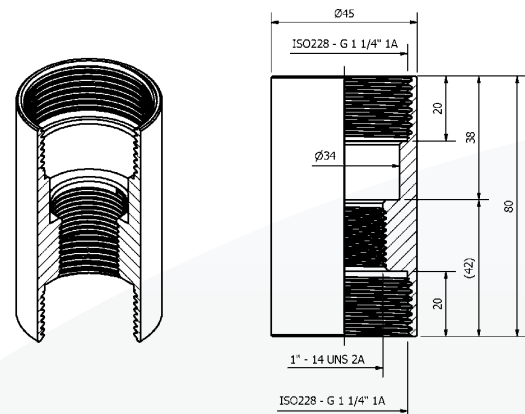

Mechanical Specification

Material: Stainless Steel SS316
Internal thread 1 (Top and Bottom): 1 1/4" 11 TPI
External thread 2 (Bottom): 1"14 TPI
Dimensions HxD: 3.15" x 1.77" (80 x 45mm)
Weight: 385g / 0.85 pounds

Order Information

Product Code	Description
ACW-651	1" 14 TPI female to Mobility thread



ACW-652

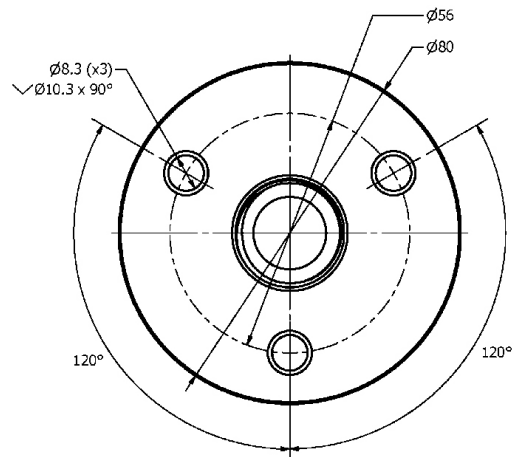

Mechanical Specification

Material: Stainless Steel SS316

External thread: 1"14 TPI

Dimensions HxD: 1.57" x 3.15" (40 x 80mm)

Weight: 250g / 0.55 pounds

Order Information

Product Code	Description
ACW-652	1"14 TPI male adapter

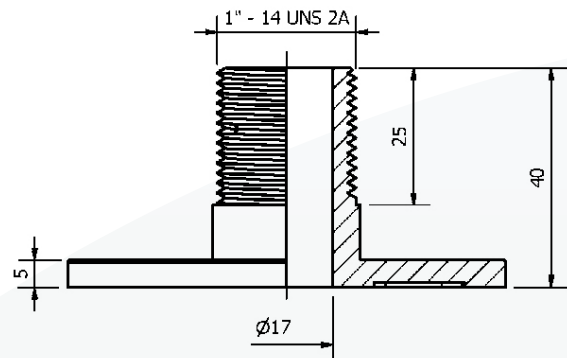

Why Rising Connection is using equipment designed and built by Peplink?

- Industry leader in both ISP & Data Bonding across multiple technology platforms
- Reliable hardware from entry level professional equipment through to advanced Enterprises solutions
- Worldwide supported and local support here in Australia by fully trained technicians
- Reliable and secure redundancy paths for mission critical sites
- Designed for maximum possible business uptime

This demonstrates to Rising Connection that you will have the Quality, Reliability and Product Support.